

Windows, Linux, MacOS... und dann?



Gliederung

- Einführung, Motivation
- Tour
- Experimente

Warum andere Betriebssysteme?

- Wozu damit beschäftigen?
 - Technische Vielfalt entdecken
 - Designphilosophien vergleichen können
 - Engagement als Entwickler?
 - + Nerd Cred
- Sofort auf eins dieser Systeme umsteigen?
 - OMG nein.

Tour



- Freier BeOS-Nachbau (Ziel: Binary Compatibility)
- Fokus: Echtzeit-Multimedia
- Stand: Pre-Alpha
- Lizenz: MIT

HAIKU





preferences

File Window



Printers



Mouse



Network



ScreenSaver



Time



Sounds



Appearance



FileTypes



Backgrounds

18 items

About This System



Haiku

Copyright ©2001-2008 Haiku, Inc.
<http://haiku-os.org>

Version:

Walter (Revision 24008)

Processor:

Intel Pentium II
2.66 GHz

Memory:

128 MB total, 79 MB used (61%)

Kernel:

Feb 19 2008 07:10:55

Time Running:

19 minutes, 45 seconds

Team Leads:

Axel Dörfler
Phil Greenway
Philippe Houdoin
Waldemar Kornewald
Marcus Overhagen
Ingo Weinhold
Jonathan Yoder

Developers:

Ithamar R. Adema
Stephan Aßmus
Andrew Bachmann
Stefano Ceccherini
Rudolf Cornelissen
Léonard Dupont



Tracker



Terminal



AboutSystem



14:17:52

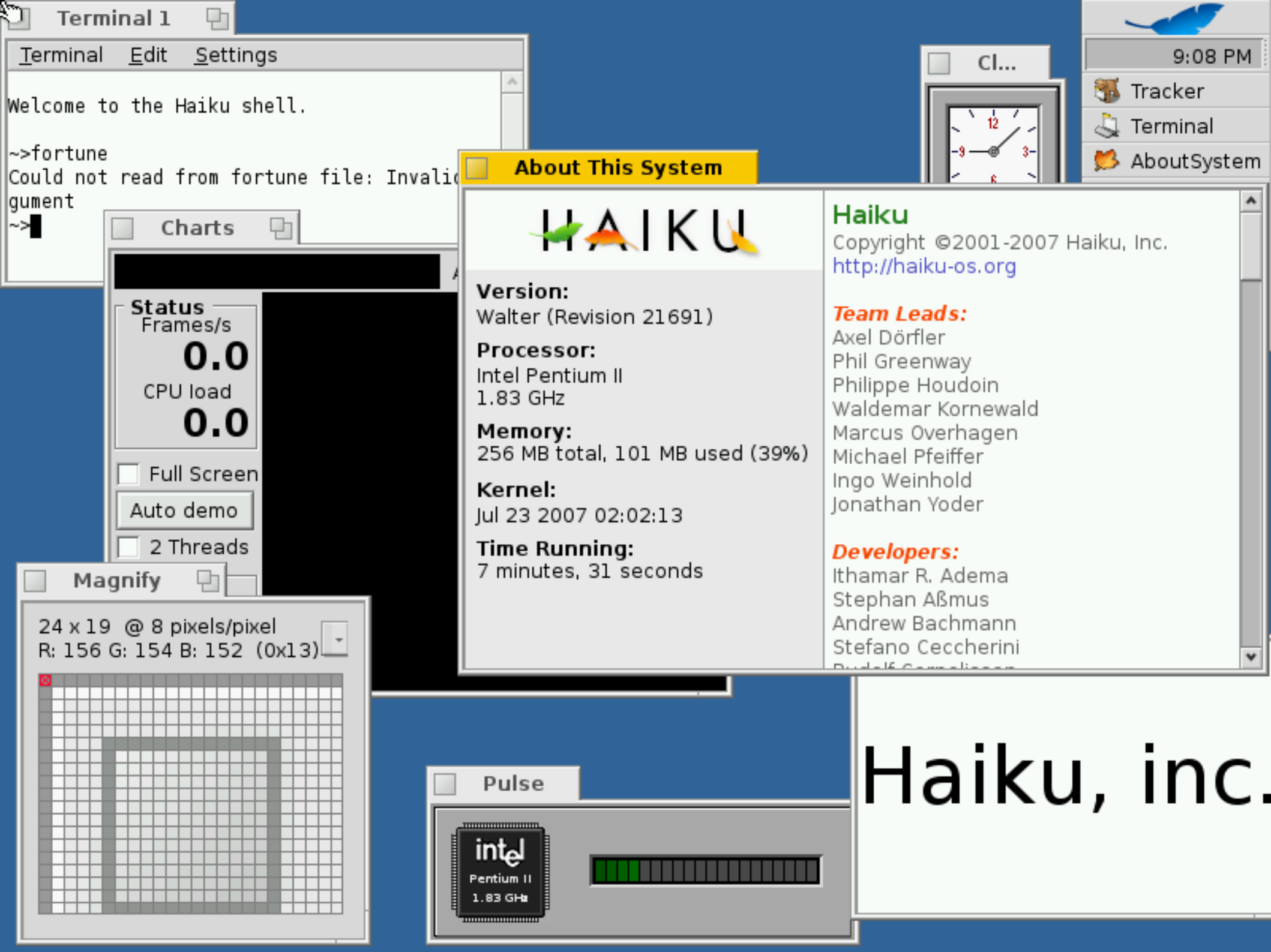

Terminal 1

Terminal Edit Settings

Welcome to the Haiku shell.

```
~>fortune
Could not read from fortune file: Invalid argument
~>
```

Charts

Status

Frames/s

0.0

CPU load

0.0

Full Screen

Auto demo

2 Threads

Magnify

24 x 19 @ 8 pixels/pixel
R: 156 G: 154 B: 152 (0x13)

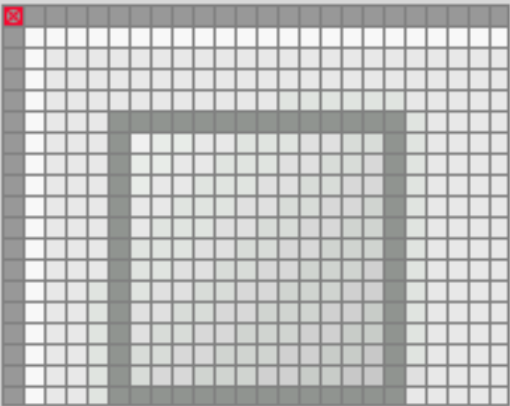

About This System



Version:
Walter (Revision 21691)

Processor:
Intel Pentium II
1.83 GHz

Memory:
256 MB total, 101 MB used (39%)

Kernel:
Jul 23 2007 02:02:13

Time Running:
7 minutes, 31 seconds

Haiku

Copyright ©2001-2007 Haiku, Inc.
<http://haiku-os.org>

Team Leads:

- Axel Dörfler
- Phil Greenway
- Philippe Houdoin
- Waldemar Kornewald
- Marcus Overhagen
- Michael Pfeiffer
- Ingo Weinhold
- Jonathan Yoder

Developers:

- Ithamar R. Adema
- Stephan Aßmus
- Andrew Bachmann
- Stefano Ceccherini
- Dudolf Cornelissen

Pulse



Haiku, inc.



- Freies Desktop-OS
- Fork von AtheOS
- Inspiriert von AmigaOS, BeOS
- Bisschen wie Linux, aber ohne Altlasten
- Lizenz: GPL

About Syllable

 Syllable 0.6.5
 Build date: Jan 4 2008
 See <http://www.syllable.org> for updates and information

Network Preferences

Interfaces **General** DNS Hosts





Name	Enabled
eth0	Yes

Properties

Default gateway

SimpleBurn 0.4.6

Application Media type Erase Settings

-  Burn CD
-  Data CD
-  Audio CD
-  Backup

SimpleBurn

Version 0.4

- Applications
- Disks
- Home
- Preferences
- Trash
- Terminal
- Welcome

- Applications
- Disks
- Home
- Preferences
- Trash
- Terminal
- Welcome

Printers

Application Printer

Add printer Remove printer Set as default

HP_Laserjet_5L

HP_LaserJet5L

Model
HP LaserJet 5L Select...

The printer HP_Laserjet_5L
is a Parallel printer connected to
/dev/printer/lp/0

Cancel Save



ReactOS

- Freier Windows-Klon
- Ziel: Kompatibilität für Programme und Treiber
- Einige Programme laufen bereits
- Lizenz: GPL

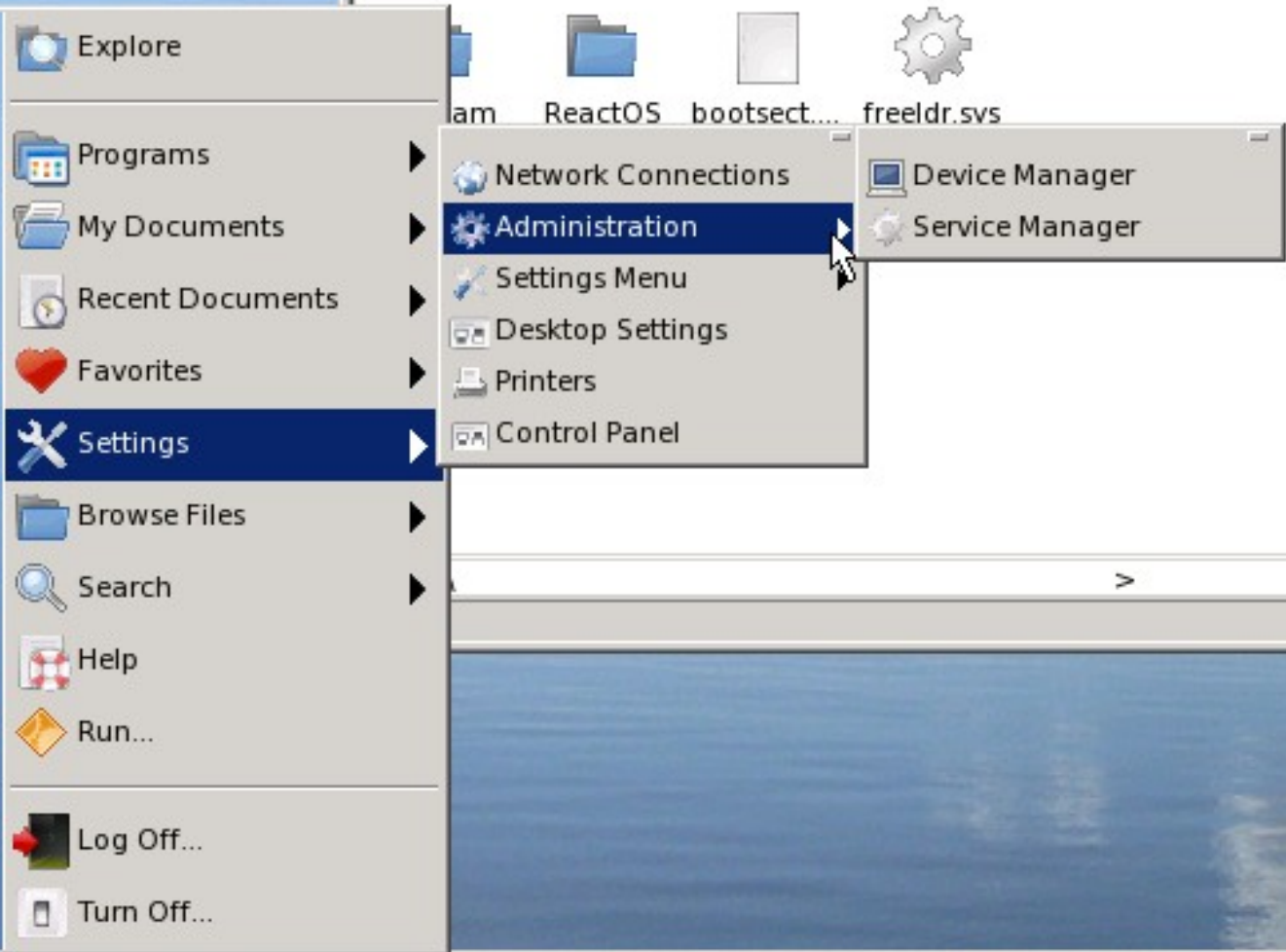
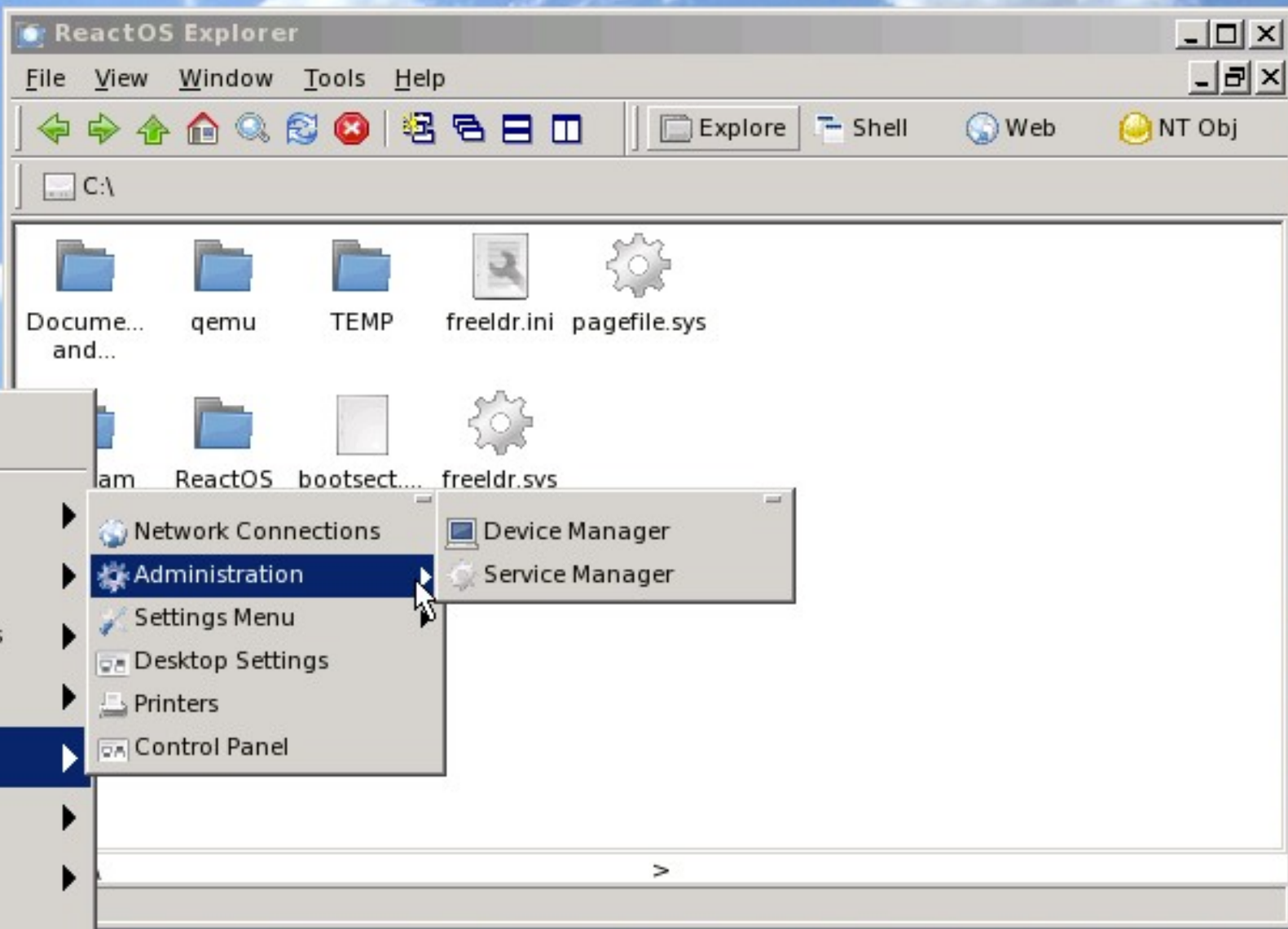

ReactOS 0.3.3

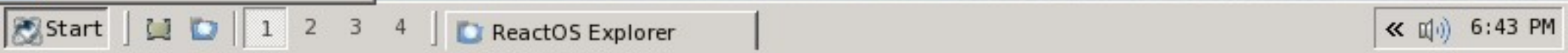

ReactOS Device Manager

File Action View Help

- COMPUTERNAME
 - Hard disks controllers
 - Generic IDE channel
 - Generic IDE channel
 - Generic PCI IDE controller
 - Keyboards
 -
 - Mice and other pointing devices
 -
 - Network Adapters
 - RTL-8029(AS)
 - Serial and parallel ports
 - COM1
 - System devices
 - Intel 440FX - 82441
 - Intel 82371AB/EB PCI
 - Intel 82371SB PIIX3
 - PCI BIOS

C:\ReactOS\sys

Driver File Details

RTL-8029(AS)

General

Driver files:

C:\ReactOS\System32\drivers\ne2000.sys

Provider:

File version:

Copyright:

Digital Signer:

OK

OK

Cancel

- AROS = AROS Research Operating System
- Stark Amiga-inspiriertes System
- Ziel: Kompatibilität mit AmigaOS 3.1
- Lizenz: AROS Public License (MPL-basiert)





AROS LIVE CD

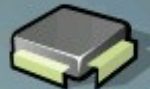

Ram Disk



AROS

AROS

Zune - Préférences générales

Test the power of BetterString here!

Background Text Font

Inactive: [] [] []

Active: [] [] []

Cursor: []

Marked: [] [] []

Frame: []

Test Sauver Utiliser Annuler

WookieeChat - gobgob connected to calvino.freenode.net - #aros [33 users]

AROS - No schedule n' rockin! :: http://www.vmwaros.org :: ~0 very ba

[05:12:49] «Join» gobgob (n=bidol@193-4-82-239-7-204.fbx.proxad.net)

[05:12:49] «Topic» 'AROS - No schedule n' rockin! :: http://www.vmwaros.org :: ~0 very bad!'

[05:12:49] «Topic» set by Ogun on Sun Nov 25 22:17:03 2007

[05:12:49] «Names» Users in channel #aros:

[05:12:49] «Names» gobgob myrkraverk redblue jahc suppahsv fce2 henes @_4pLaY_ GeneralTom fishy_fis _Lucretia__bernie Jupp3 ekix +BTTCbot Ball000 NomadOfNorad Blacky_Stardust _bernie/home Ex-Cyber Rhalto jimtabor siggjen zerohero DaMato[AW] nighty-threeseas alain__ Golem nicomen__ lastebil chii @ChanServ:

[05:12:49] -ChanServ- [#aros] Welcome to the Official AROS IRC channel

[05:16:51] «Join» redblue (i=star@ppp192.108-253-207.mtl.mt.videotron.ca)

[05:19:59] «Quit» redblue (i=star@ppp192.108-253-207.mtl.mt.videotron.ca) (Read error: 104 (Connection reset by peer))

[04:10:57] «Quit» redblue (i=star@ppp192.108-253-207.mtl.mt.videotron.ca) ("You cannot do a kindness too soon because you never know how soon it will be too late." -RWEE)

[04:11:09] «Join» redblue (i=star@ppp192.108-253-207.mtl.mt.videotron.ca)

[04:11:48] <redblue> mooooooooo

@_4pLaY_ ChanServ BTTCbot _bernie _bernie/home _Lucretia_ alain Ball000 Blacky_Stardust chii DaMato[AW] ekix Ex-Cyber fce2 fishy_fis GeneralTom gobgob Golem henes jahc jimtabor Jupp3 lastebil myrkraverk nicomen_

chat.eu.freenode.net 6667 no #aros

Work:Network

Archives AROS Exec Download Tool

Work:Networking

- AROS Exec Recent
- AROS Exec Full
- OS4 Depot Recent
- OS4 Depot Full

Download Index Parse Index

game/roleplaying/frotz.i386-aros.tar.bz2
game/roleplaying/gluxe.i386-aros.tar.bz2
game/roleplaying/ztools.i386-aros.tar.bz2
game/strategy/text-elite.i386-aros.tar.bz2
graphics/convert/aros-gocr039.i386.zip
graphics/convert/dcrow-sse2.i386-aros.zip
graphics/convert/dcrow.i386-aros.zip
graphics/convert/jpeg-6b_bin.i386-aros.zip
graphics/convert/jpeg-6b_src.i386-aros.zip
graphics/convert/potrace.i386-aros.zip
graphics/convert/potrace_src-aros.zip
graphics/convert/zune-gocr-0.39.i386-aros.zip
graphics/convert/zune-gocr-0.39_src-aros.zip
graphics/edit/lunapaint_v033c.tar.gz
graphics/edit/sng.i386-aros.tar.bz2
graphics/icon/ams_vcs3d_part-1_60.lha
graphics/icon/cartoonish.zip
graphics/icon/wd_png.zip
graphics/misc/head.i386-aros.zip
graphics/misc/head_src-aros.zip
graphics/misc/slideshoww.lha
graphics/theme/anaroswallpaper-01.i386.zip
graphics/theme/arosborderthemes.zip
graphics/theme/glass.wdz
graphics/theme/glass_hack.wdz

Information

Category graphics/icon
Filename cartoonish.zip
Size 710693
Date 20051126-08.35
Version
Description 64x64 png icons

Download README Show README Download Archive...

AROS:Prefs

AROS:Prefs

Presets AHI ConfigP EditPrefs Font IControl Input

Locale ReqTools ScreenMode Serial Theme Time Trackdisk

Wanderer Zune

- Desktop-Betriebssystem
- Ein-Mann-Projekt
- Perpetual Beta
- Proprietär (kostete: 25€)
- Bis auf weiteres eingestellt (Jan. 2009)



Storage

System Manager

Terminal

Firefox

Thunderbird

Viewer - /boot/addon/backgrnd/Images

File View

Preview

Query

Images

Videos

Music

Custom

File

File	Size
blue6.jpg 1152x864, 32 bpp	82.89 KB
blue7.jpg 1600x1200, 32 bpp	285.82 KB
brick.jpg 1280x1024, 32 bpp	252.66 KB
brushed.jpg 1600x1200, 32 bpp	114.22 KB
burning.png 1600x1200, 32 bpp	618.81 KB

Favorites

MediaCenter



Audio: 48000 Khz, 16 Bit, Stereo (Codec: wmv2)

Open

DataCollectionEditor - WindUI Settings

File	Key	Type	Data
	EnableVistaLikeTransparentBor...	BOOL	true
	ColorizeBorder	BOOL	false
	ColorizeBorderColor	COLOR	#00000000
	FrameBackgroundColor	COLOR	#00C1C1C1
	ClientBackgroundColor	COLOR	#00EBEBEB
	FrameBorderWidth	INT32	10

USB Hub

5/5

- eventviewer.app
- System Manager
- Terminal
- Firefox
- Thunderbird
- Storage

System Manager - About

SkyOS Build 6799 for i586
This is a beta product.

Credits

skyos

Copyright (c) 1996 - 2007
Robert Szeleney
<http://www.skyos.org>

Copyrights

Selected graphic mode applied.

Profiler

Function	Self
smbd_fork_fork (PID 76)	9
nmbd_fork (PID 68)	4
indexfeeder.app (PID 49)	6
viewer.app (PID 77)	3
panel.app (PID 36)	15
vci.app (PID 79)	2
appman.app (PID 38)	1
vci.app (PID 95)	50
Functions	50
WaitQueues	
Sleeps	
Exceptions	
Interrupts	
Locks/Semaphores	
viewer.app (PID 101)	18
Functions	18
<unknown symbol>	0
main	0

0 us 1000 us 2000 us 3000 us 4000 us 5000 us

```

app_t81 PID 81
werApp PID 77
ure_app PID 46
listener PID 69
nan_app PID 38
bash PID 96
ssd_fork PID 65
top_app PID 34
itor_app PID 67
wThread PID 84
checker PID 53
bash PID 80
der_app PID 49
transp PID 19
ork_fork PID 76
Thread PID 103
ibd_fork PID 72
bug_app PID 41
ibd_fork PID 68
vcrApp PID 35
aretools PID 64
vci_app PID 79
ork_fork PID 75
Loader PID 102
i_app_t1 PID 71
nan_app PID 38
rice_app PID 67
inel_app PID 36
ork_fork PID 80
wThread PID 82
iss_app PID 51

```

Viewer - Query - mimetype=image* && Image.Width>1200

Navigation

- Places
- Queries
 - DataCollections
 - Firefox related files
 - My MP3 files
 - Past 5 minutes
 - Past week
 - Today
 - Yesterday
 - mimetype=image* && Image...

Query

Search for
type=image* && Image.Width>1200

Preview

File	Location	Size	Last modified
background...	/boot/programs/mediacenter/re...	33.74 KB	Mon Dec 1 07:47:14 2003
1280.jpg	/boot/system/login/	20.83 KB	Mon Oct 8 06:12:28 2007
021_17a.jpg	/boot/addon/images/	673.59 KB	Tue Oct 30 12:02:12 2007
preview.jpg	/boot/system/plugins/themes/w...	166.71 KB	Mon Oct 8 06:12:50 2007
023_19a.jpg	/boot/home/admin/usbdisk_bac...	909.22 KB	Tue Oct 30 12:06:44 2007
005_1a_1.jpg	/boot/home/admin/usbdisk_bac...	999.96 KB	Tue Oct 30 12:08:19 2007
006_2a_1.jpg	/boot/home/admin/usbdisk_bac...	920.80 KB	Tue Oct 30 12:08:27 2007
005_1a_2.jpg	/boot/home/admin/usbdisk_bac...	960.38 KB	Tue Oct 30 12:11:44 2007

Terminal /boot/home/adm

```

bash-3.00#

```

Delta: 0

visopsys

- GUI-zentriertes OS
- (quasi) Ein-Mann-Projekt
- Leistungsfähiger Partitionseditor
- Lizenz: GPL



Computer



File Browser



Command Window



Programs



Administration

Enter filename

Please enter a configuration file to edit:

(up)

administration.conf

desktop.conf

filebro
wse.conf

kernel.conf

mount.conf

network.conf

programs.conf

window.conf

administration.conf

System Device Information

```

system
  framebuffer graphic adapter
  "AMD AMD Athlon(tm) XP 2500+" x86 CPU
  vendor.string=AuthenticAMD
  cpu.type=00
  cpu.family=06
  cpu.model=0a
  cpu.rev=00
  cpu.features=0383fbff
memory
  memory.size=162752 Kb
BIOS (32-bit)
PIC
system timer
real-time clock (RTC)
DMA controller
PCI bus controller
  USB bus controller
  controller.type=UHCI
  IDE disk controller
  "VMware Virtual IDE Hard Drive" IDE disk
  disk.multisectors=64
  disk.features=UDMA2
  "VMware Virtual IDE Hard Drive" IDE disk
  disk.multisectors=64
  
```

Administration

Configuration Editor

Console Window

Devices

Disk Manager

Display Settings

File Systems

Install

Keyboard Mapping

Network

Program Manager

User Manager

Visopsys Disk Manager

File Disk Partition

Disk 0: [hd0] 78533 Mb, 10011 cyls, 255 heads, 63 secs/cyl, 512 bytes
 Disk 1: [hd1] 19541 Mb, 2491 cyls, 255 heads, 63 secs/cyl, 512 bytes



Disk Partition	Filesystem	Cylinders	Size(Mb)	Attributes
hd0a Linux	ext	0-5735	45002	primary
hd0b FAT32 (LBA)	fat16	5737-5741	39	primary/active
hd0c Linux swap on Solaris	linux-swap	5742-5868	996	primary
Empty space		5869-10010	32490	

Create

Set active

Move

Defragment

Format

Delete all

Delete

Hide/unhide

Info

Resize

Undo

Write changes



Computer



File Browser



Command Window



Programs



Administration

File Browser [minimize] [maximize] [close]

File View

/system/wallpaper



View "japan.jpg" (66%) [minimize] [maximize] [close]





- (fast) reines Java-Betriebssystem
- Ziel: alle Java-Programme sollen laufen
- Basiert auf OpenJDK und GNU Classpath
- Lizenz: LGPL

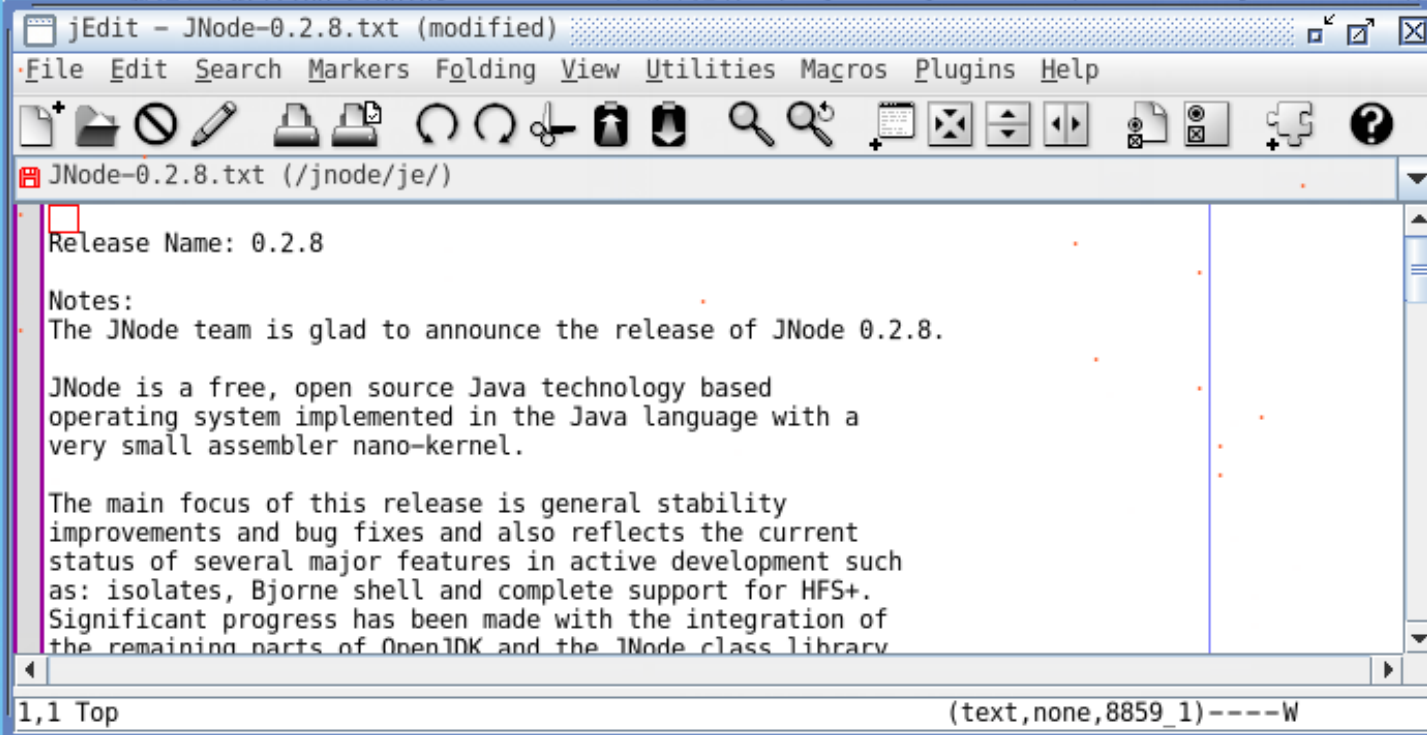
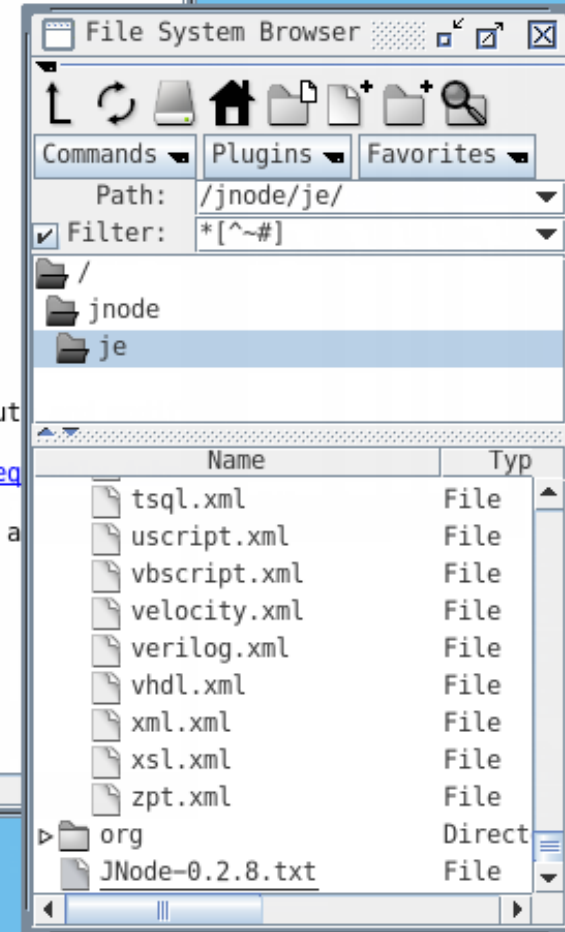
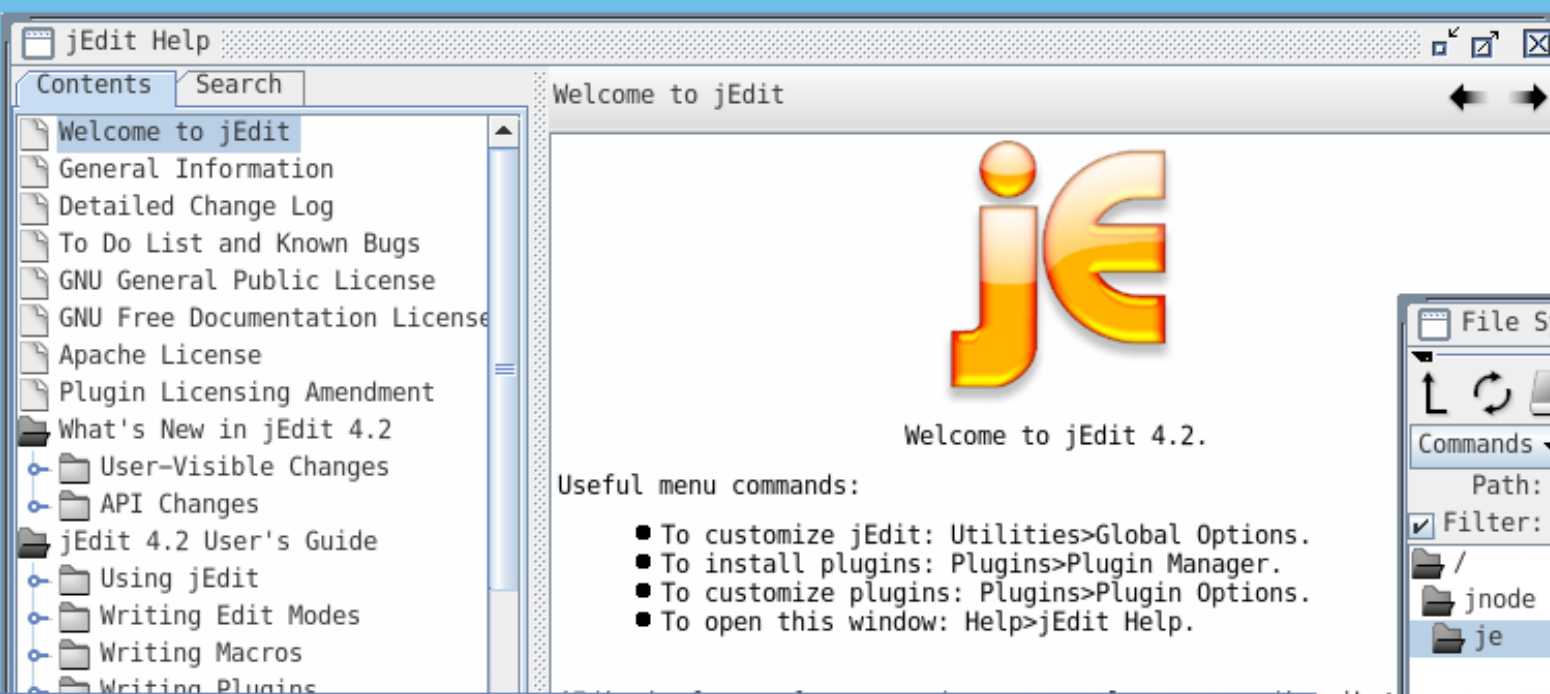

```
Console
JNode /jnode/jfreechart-1.0.10> run SuperDemo.jns
Setting jnode.debug to true
JNode /jnode/jfreechart-1.0.10> _
```

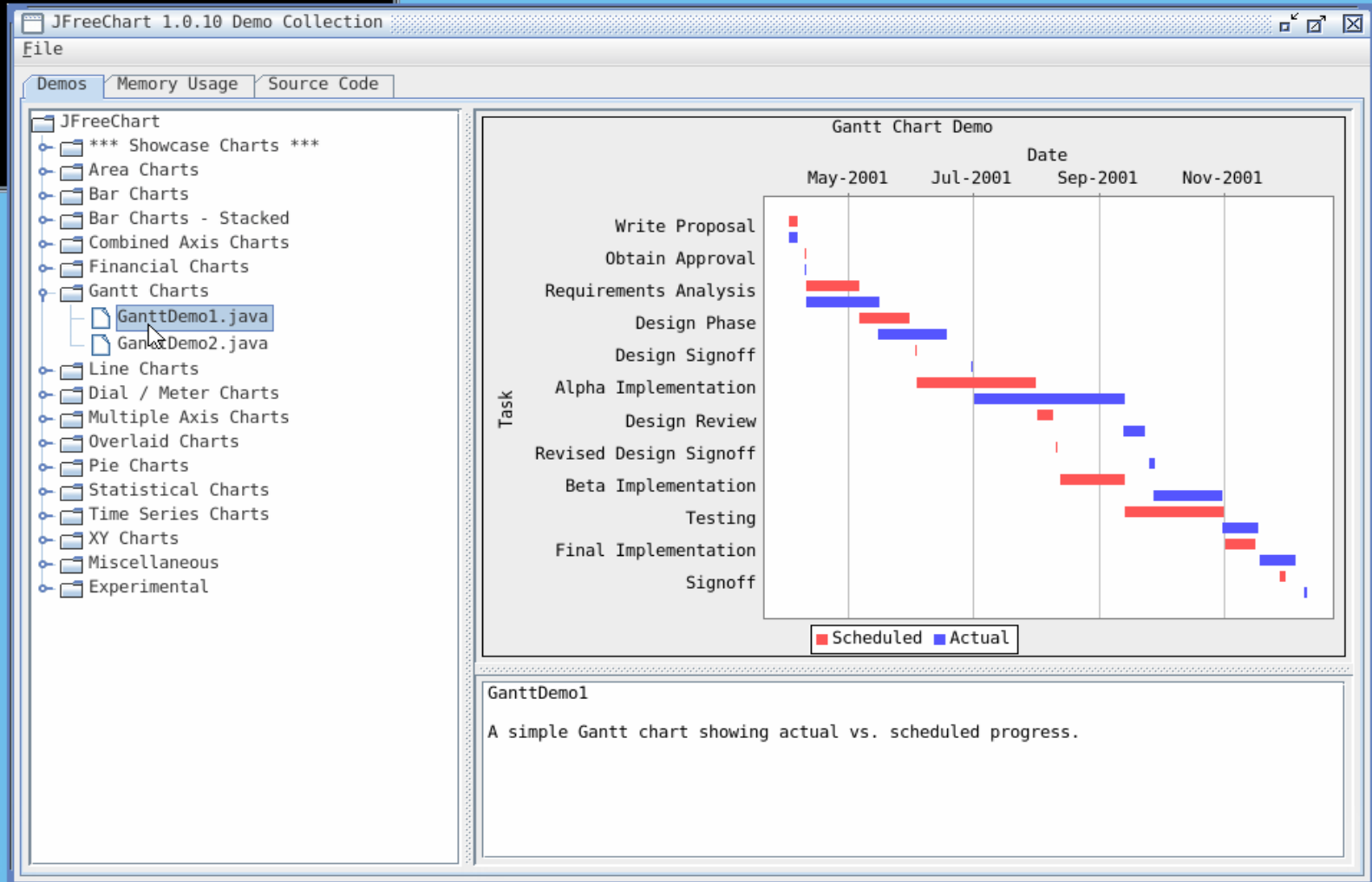

- Reines x86/64-Assembly-OS
- Passt auf eine Diskette
- GUI mit Icons, Fenstern, Transparenz etc.pp.
- Lizenz: eigene
- Fork: KolibriOS

MenuetOS.net



FILES



FRSM



WRITE



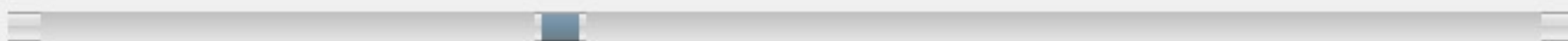

LOAD DVD PLAY STOP

Video: MPEG-2 Resolution: 720x576 Status: Dvd loaded
Audio: Not supported Framerate: 25 fps(d) ARatio: 16:9



Graphics editor <<ANIMAGE>> V 1.1
 FILE EDIT INSTRUMENTS PALETTE FILTERS ANIMATION HELP



TINYPAD 4.0.5

Файл Правка Поиск Запуск Кодировка Опции

of counter. For example:

```
rept 8 n:0 ( pxor xmm#n,xmm#n )
```

will generate code which will clear the contents of eight SSE registers. You can define multiple counters separated with commas, and each one can have different base.

The "irp" directive iterates the single argument through the given list of parameters. The syntax is "irp" followed by the argument name, then the comma and then the list of parameters. The parameters are specified in the same way like in the invocation of standard macroinstruction, so they have to be separated with commas and each one can be enclosed with the "<" and ">" characters. Also the name of argument may be followed by "*" to mark that it cannot get an empty value. Such block:

```
irp value, 2,3,5
  ( db value )
```

will generate lines:

```
db 2
db 3
db 5
```

The "irps" directive iterates through the given list of symbols, it should be followed by the argument name, then the comma and then the sequence of any symbols. Each symbol in this sequence, no matter whether it is the name symbol, symbol character or quoted string, becomes an argument value for one iteration. If there are no symbols following the comma, no iteration is done at all. This example:

CPUID 2.21 by S.Kuzmin & the KolibriOS team

Internal name: n/a
 Multiplier: 05.0 System clock: 0014.93 MHz
 Frequency: 0074.69 MHz Technology: 0.28 micron
 CODENAME: Intel Pentium II (Klamath)
 CPU VENDOR: GenuineIntel
 FAMILY: 6 std 06 ext
 MODEL: 3 std 03 ext
 STEPPING: 3
 L1(data): 000 KB 00-way set 00-byte line size
 L1(inst): 008 KB 04-way set 32-byte line size
 L2: 0128 KB 04-way set 32-byte line size
 L3: 00000 KB 00-way set 00-byte line size
 Brand: n/a Type: OEM

Instruction sets

MMX:	yes	MMX+:	no	3DNow!:	no	HTT:	no
SSE:	yes	SSE2:	yes	3DNow!+:	no	SSE3:	yes

Press for more Available RAM: 0111 out of 0128 MB



Calc 1.32

dec

0000000777.

A	B	C	D	E	F	C
1	2	3	+	Int	Sin	Asin
4	5	6	-	1/x	Cos	Acos
7	8	9	/	x^2	Tan	Atan
+/-	0	.	*	Sqr	Pi	=



- Betriebssystem für Bastler (C64-inspiriert)
- Nur für x86-64
- Kein Speicherschutz, kein virtueller Speicher...
- Immer überall Zugriff auf alles
- Lizenz: Public Domain

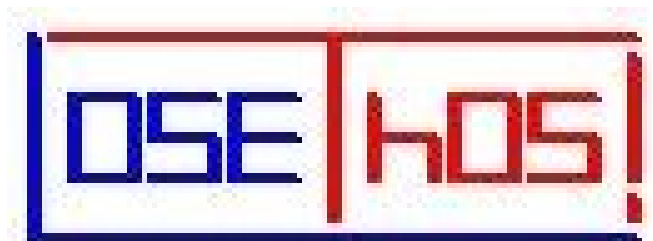

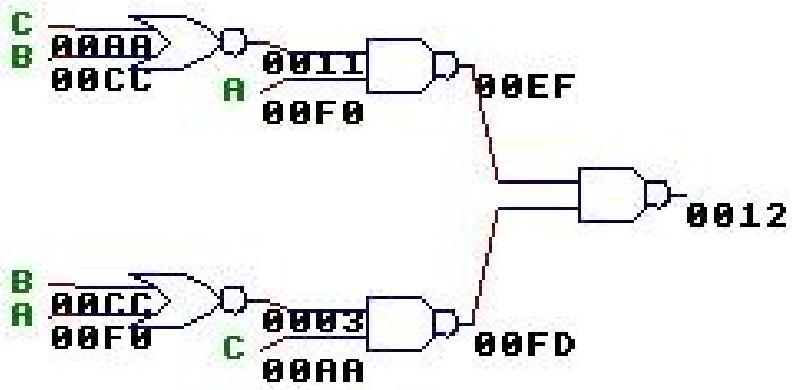

- E+1 System Src Code
- Quick Reboot
- Introduction
- Help Index
- Take tour
- Key Map

-1 Applications

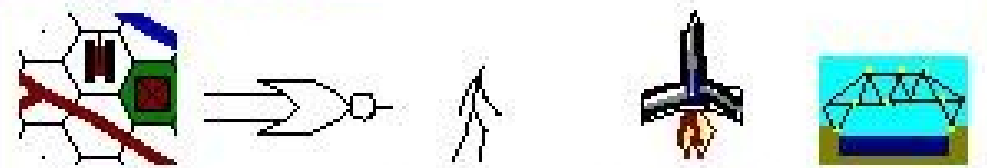

Tanks Logic MarGame Timeout Span

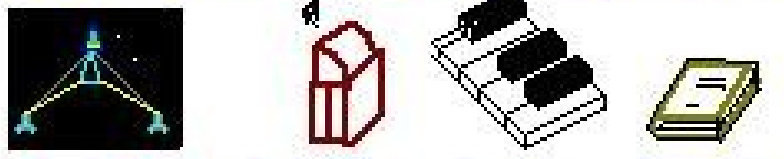

X-Caliber JukeBox Organ Vocab

-1 Game Starters

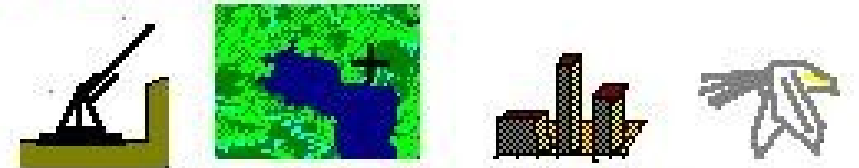

BigGuns FlightSim MisDef BirdLand

MENU artUp.IXZ...D: [X]

OSE | HOS |

V5.05

Undo:0000 WH Line:0001 Col:0001

CPU#7 001010:0000 4.27m
 CPU#6 001010:0000 4.27m

CP Turn: 1 Player 1: 32 Player 2:

CP
CP
CP
CP
CP
CP
CP
CP
CP
CP
CP

00000000000000
 00000000000000
 ctions=953 bytes=00085425

Term

```

TAB/User.MUZ... [X]
$MA,"M(\D:\LT/*\","E:\LT/*\","+r+d\"
$MA,"M(\D:\LT/*\","F:\LT/*\","+r+d\"
$ID,-2$$MA,"ChangeDisk('T');\r"$
$MA+A,"MenuBoot D","QMenuBoot('D');\r"$
$MA+A,"Take Tour","Cd(\"::/LT/Accts/Tou
$MA+A,"Update and Compile Drive","Promp
$MA+A,"Just Update Drive","PromptUpdate
$TR-C,"Stuff for Burning CDs"$
$ID,2$$MA+A,"Make Inhouse CD Image","Ma
$MA+A,"Make Inhouse DVD Image","MakeInh
$MA+A,"Make Lite CD Image","MakeLitePro
$MA+A,"Copy Inhouse CD Image","CopyInho
$MA+A,"Make Production CD Image","MakeP
$ID,-2$$TR-C,"Applications"$
$ID,2$

```

\$PI+LM+PU,"WarGame","Cd(\"::/LT/Apps/Wa

```

TAB/User.MUZ... [X]
Install From CD to D
UpdateEE
-| Merge Files Stuff
M("D:/://*"."I:/://*","+r+d"):
M("D:/://*"."E:/://*","+r+d"):
M("D:/://*"."F:/://*","+r+d"):
ChangeDisk('T');
MenuBoot D
Take Tour
Update and Compile Drive
Just Update Drive
-| Stuff for Burning CDs
Make Inhouse CD Image
Make Inhouse DVD Image
Make Lite CD Image
Copy Inhouse CD Image
Make Production CD Image
-| Applications

```



WarGame JukeBox Rocks Vocab FlightS

\$PI+LM+PU,"Timeout","Cd(\"::/LT/Apps/Ti

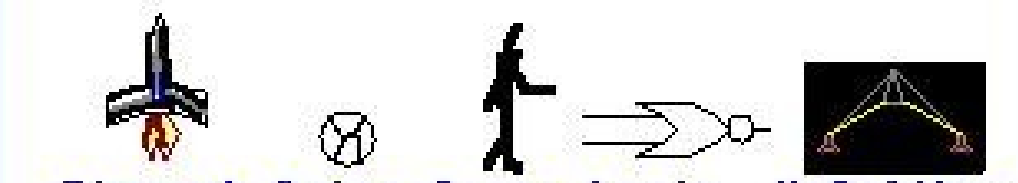

Timeout Swing Goons Logic X-Caliber

\$PI+LM+PU+UL,"BigGuns","#include \"::/L

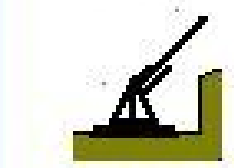

BigGuns

```

$MA+A,"MusicOrgan","MusicOrgan(\"HOME/P
$MA+A-X+PU,"Digits (Memory Game)","Cd(\
$MA+A-X+PU,"Bling (A fractal-like thing)
$MA+A-X+PU,"CPUPlot","#include \" /LT/De
$MA+A-X+PU,"SpaceShip Game","#include \
$ID,-2$
$MA+A-X+PU,"List functions in alphabeti
$MA+A-X+PU,"List functions in numeric a
$LK,"Bible","BF:Genesis,"$

```

- MusicOrgan
- Digits (Memory Game)
- Bling (A fractal-like thing)
- CPUPlot
- SpaceShip Game

```

$MA+A+PU,"Quick Reboot E:","Boot(\"E:<B
$MA+A,"Compile E","CompileDrive('E');\r

```

- List functions in alphabetic order
- List functions in numeric address orde
- Bible
- Quick Reboot E:
- Compile E

Plan 9



- Entwickelt von Bell Labs, Unix-Erfindern
- Everything is a file
- Erstes System mit voller UTF-8-Unterstützung
- Lizenz: Lucent Public License (ähnlich IBM-P-L)











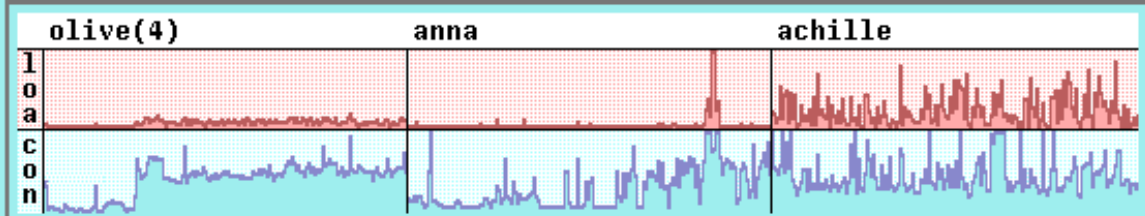

rsc /dev/n jmk skipt tklopp john brucee lorenz
 12:17 11:47 11:16 02:50 02:05 02:03 Jun 10 Jun 10



Mail Newcol Kill Putall Dump Exit

```

%g scat
ori
638 items
plot nogr

```

```

New Cut Paste Snarf Sort Zerox Delcol
/mail/fs/mbox/34/ Del Snarf | Look Reply all Delmesg Save

```

```

New Cut Paste Snarf Sort Zerox Delcol
/acme/mail/guide Del Snarf | Look

```

```

====> 3/ (multipart/mixed) [inline]

```

```

Mail stored
plumb /mail/box/$user/names
mail -'x' someaddress
mkbox /mail/box/$user/new_box

```

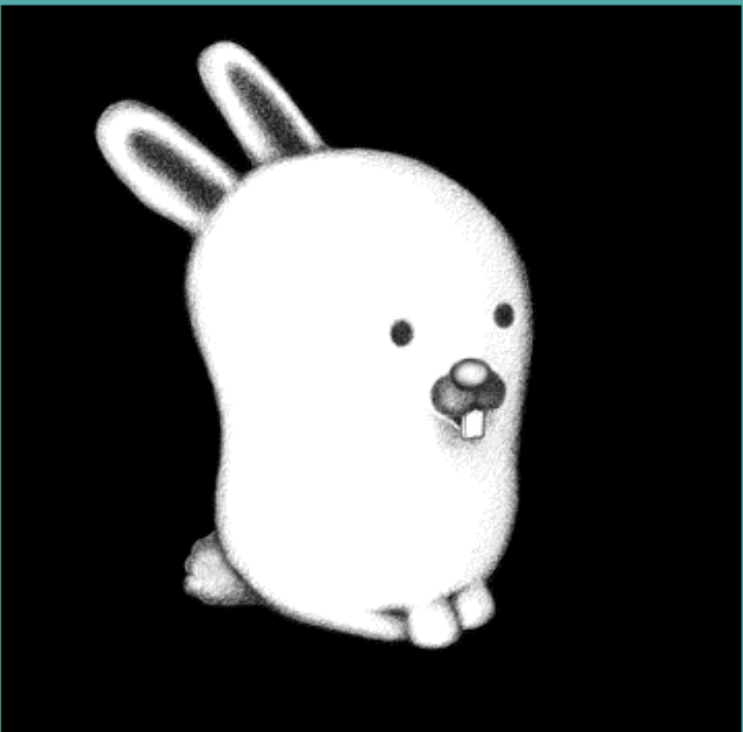

```

jmk@plan9.bell-labs.com rsc@plan9.bell-labs.com
...
body.jpg /usr/rob/plan9bunnysm.jpg

```

```

/mail/fs/mbox/ Del Snarf | Look Put Mail
34/ Russ Cox <rsc@plan9.bell-labs.com> Sun 11 Jun 12:17

```

```

34/1/ (text/plain)
34/2/ rob pike <rob> (text/plain)
34/3/ renee french <cornelia@world.std.com>
34/3/1/ (text/plain)
34/3/2/ (image/jpeg)
34/3/3/ (text/plain)

```

```

33/ /dev/null Sun 11 Jun 11:47
32/ jmk Sun 11 Jun 11:16
32/1/ (text/plain)
32/2/ DAGwyn@aol.com (text/pl

```

```

/usr/rob/lib/plumbing Del Snarf | Look
# to update: cp /usr/$user/lib/plumbing /mnt/plumb/rules
editor = acme

```

Plan 9 from Bell Labs

3-6 augrim, 4 -ym, 5 -ime, -ime, 7 agrum, algrim. β. 4-6 aljarosme, algorism(e, augrisme, 7-9 algorism, algorithm. [a. OFr. augorisme, algorisme, augorime; ad. med.L. algorism-us (cf. Sp. guarismo cipher), f. Arab. al-Khowārizmī the native of Khwārazm (Khiva), surname of the Arab mathematician Abu Ja'far Mohammed Ben Musa, who flourished early in the 9th c., and through the translation of whose work on Algebra, the Arabic numerals became generally known in Europe. (Cf. 'Euclid' = plane geometry.) Algorisme being popularly reduced in OFr. to augorime, English also shows two forms, the popular augrime, ending in agrim, agrum, and the learned algorism which passed

```

window
x
x.gif
y
日本語
%g ech
%g ↓

```

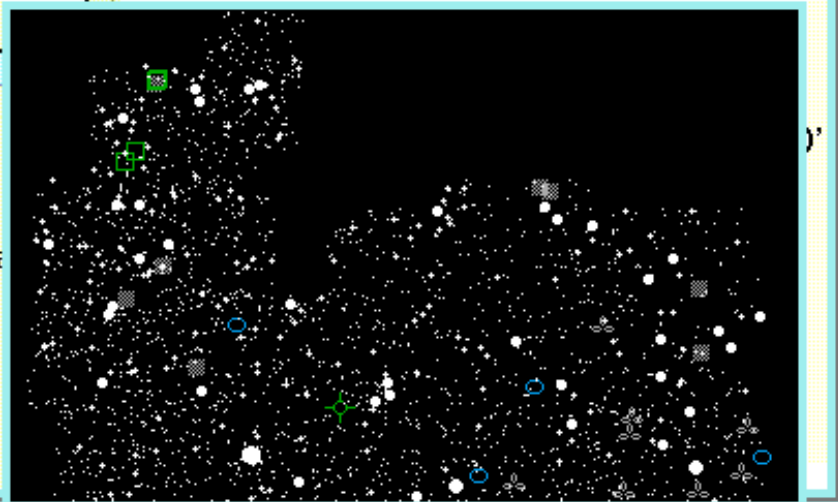



plan9
 l
 e
 s 1432
 i
 m

Tue Jul 15 12:34



mirtch
 12:34

```
plan9% echo 'hello there'
! mail -s 'hello' andrey
plan9% !
```

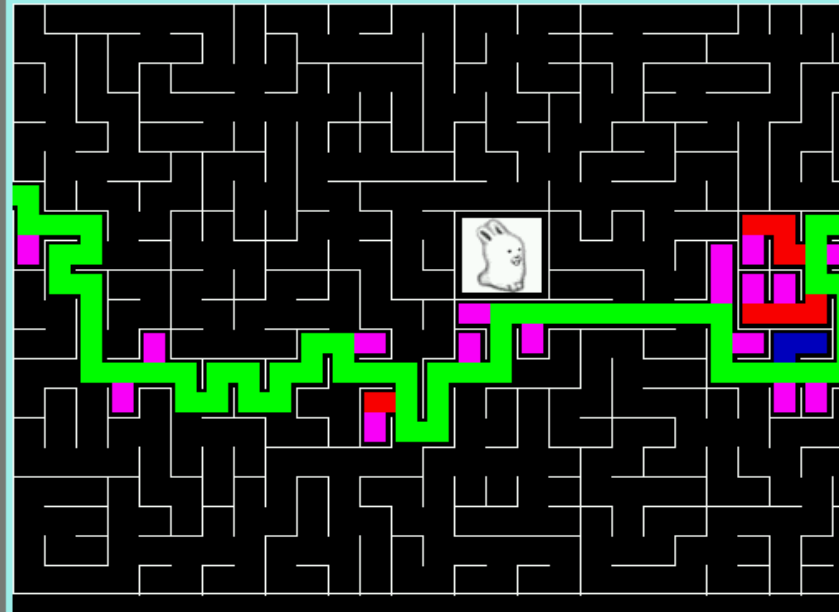

```
abcdefghijklmnopqrstuvwxyz ΕΘμΆΕÖPßéöÿ%
--'"" ,!_~"æšÿž€ ΑΒΓΔΩαβγδω ΑΒΒΓΔαδβγδ%
θæRΛυε∞ ↑±ϖ; ı†F⊕⊗⊙⊚ Α?∂₂ήΒιΨε:λκλς%
c_R
Greetings in various languages:%
c_R
Hello world, Καλημέρα κόσμε, %%%%%
c_R
Box drawing alignment tests:
c_R
c_R
plan9% !
```

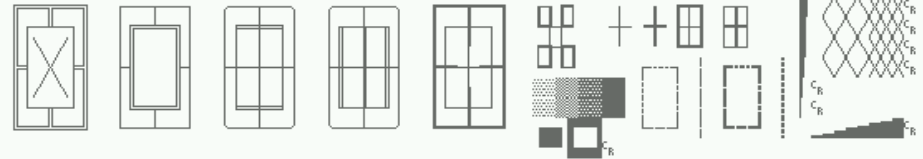

Mail Newcol Kill Putall Dump Exit
 New Cut Paste Snarf Sort Zerox Delcol
 /mail/fs/mbox/ Del Snarf | Look Put Mail Delmesg
 1/ mirtchov@cpsc.ucalgary.ca Tue 15 Jul 12:34
 hello
 /mail/fs/mbox/1/ Del Snarf | Look Q Reply all Delmesg Save
 From: mirtchov@cpsc.ucalgary.ca
 Date: Tue Jul 15 12:34:32 MDT 2003
 To: andrey
 Subject: hello

hello there

```
--%Global%- -- (UniBG Team) --
-%SocksCleaner%- Hosta vi shte byde skaniran za oper
*%>%* You have joined channel #!/bin/sh
*%T%* Topic for #!/bin/sh: <unsubishte> e she donesa
*%T%* Topic for #!/bin/sh set by xelishte on Tue Jul
*%#%* Users on #!/bin/sh: f2f_ matematich @avatarisht
e_ @chervarium @xuslesaew
*** #!/bin/sh : created Wed Jun 11 02:19:39 2003
<%f2f_%> hola
<informix> bonjour, f2f_
<%f2f_%> pisaneto pod plan9 ruley :)
<%f2f_%> plan9% bind '#!' /tmp
<%f2f_%> plan9% cd /tmp
<%f2f_%> plan9% window -m
<%f2f_%> plan9% cat > data1
<%f2f_%> hola
<%f2f_%> pisaneto pod plan9 ruley :)
[%f2f%] test
>%f2f_%< testis!
[%f2f%] testis!
>%f2f_%< test
<unsubishte> #! kakwo e ? :)
<%f2f_%> pipe
<unsubishte> #?
<informix> # is the number of the channel or a sharp or a pound or octothorpe or hash or a g
rid or Tic Tac Toe
<v0rbe_> f2f_, i kvo prai tva?
!
```

```
mirtchov@fbsd$ xv
!
```

```
/join #!/bin/sh nohelp
hola
pisaneto pod plan9 ruley :)
/msg f2f_ testis!
/msg f2f_ test
pipe
!
```



eComStation

- Aufgemöbeltes lizenziertes IBM OS/2 Warp
- Aktuelle Software und Treiber
- (ziemlich) kostenpflichtig
- Lizenz: proprietär

Pixel - unfiled6.px

File Edit Image Animation Layer Effects Select Settings Window Help BugReport

Helvetica Regular 32 Download Undo

Pavel Kanzelsberger English

Tools

untitled4.px @ 100% (CMYK/ISO Coated)

untitled5.px @ 100% (RGB/sRGB IEC61966-2.1)

untitled6.px @ 100% (RGB/PhotoGamutRGB_avg6c)

Scanner Access Now Easy v1.0.16

Device: Noname frontend-tester (test:0)

Scan Mode

Scan mode: Color

Bit depth: 8

Hand-scanner simulation

Three-pass simulation

Scan resolution: 50 DPI

Special Options

Select the test picture: Color pattern

Read limit

Read delay

Return-value of sane_r...: Default

Loss of pixels per line: 0 px

Fuzzy parameters

Use non-blocking IO

Offer select file descriptor

Enable test options

Device: Noname frontend-tester (test:0)

Preview Acquire

Colors

Color Palette Style Histogram

RGB 53 81 114

Web tools

Optimize Color table Slice Map

GIF Preset Options

Auto

Diffusion 100 16

Transparency: No transparency

Auto update on change Optimize

Layers

Layer Channel Path Clipboard

Normal 100

Background Normal: 393x393 [0,0]

Preview

Tool options

Text tool

Create or edit text objects

Font: Helvetica 32

Image Selection Regular

Rotate: 0 Kerning: 0

Baseline: 0 Leading: 1

Locale: english Key: cz

Auto kerning Options

Spell checking Effects

Use text hyphenation

Show bounding boxes

Workspaces

0/0kb (13Mb) Text tool, used to insert or modify text in image

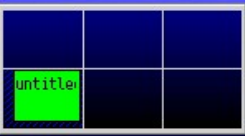
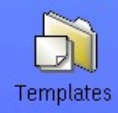

- Local System
- Shots
- Local Network
- Internet
- Programs
- Templates
- OpenChat/2
- StarOffice 5.1
- PMView Pro

- Internet
- Local Network
- Local System
- OpenChat/2
- PMView Pro
- Programs**
 - Development
 - Games
 - Installed Software
 - Multimedia
 - Utilities
- Shots
- StarOffice 5.1
- Templates
- Trash Can

Desktop

Lockup now

Suspend...

Restart Desktop...

Run...

Shut down...

OSNews.com - Mozilla Firefox

File Edit View History Bookmarks Tools Help

http://www.osnews.com/

Google OSNews Admin GeenStijl Blog News Apple BeOS Windows Linux/OSS X OS VU Misc

	News Archive	Originals	Staff Blog	Jobs.OSNews	SEARCH
	View Topics	Submit News	OSGalaxy	Contact Us	

Logged in as [Thom_Holwerda](#) [[prefs](#) | [999 comment votes](#) | [366 days left of subscription](#) | [logout](#)]

Interview with David Turner of Freetype

Written by [Eugenia Loli-Queru](#) on 2007-06-28 21:39:35 UTC

Today we feature a very interesting interview with David Turner, one of the main [Freetype](#) developers, discussing the project's past and future. These days, David continues his work in Freetype even after having been hired by Google.

[Read more](#) · [10 comments](#) · (14)

Microsoft To Simplify Downgrades From Vista to XP

Linked by [Thom Holwerda](#) on 2007-06-28 21:39:20 UTC, submitted by [jaysen.knight](#)

Microsoft is [simplifying the processes](#) via which its PC-maker partners will be able to provide 'downgrade' rights from Windows Vista to Windows XP for their customers. Microsoft will implement the first of the policy changes for its Gold Certified (top-tier) OEM partners within the next couple of weeks. The company will streamline downgrade-rights policies and procedures for the broader channel somewhat later, said John Ball, general manager of Microsoft's US Systems Group.

[39 comments](#) ·

JTC, submitted by [SEJeff](#)

The Ubuntu developers are moving very quickly to bring the Open Source Community has to offer. Gutsy Gibbon 7.10, and with this new alpha release comes a [whole](#)

Server

JTC, submitted by [Vanders](#)

yIcon 2007. The first was a new web browser, based over, which will bring together the Syllable GUI with the m that compliments Syllable on the desktop. Syllable option and will look and feel as much like Syllable as

Problem Determination Tools

- Archive Viewer
- Calculator
- Clipboard Viewer
- CPU Monitor
- eCenter
- eComCenter Install/Configure
- Enhanced Editor
- Help Viewer
- Icon Editor
- Logical Volume Manager (Advanced)
- Picture Viewer
- Seek and Scan Files
- Shredder
- Text Editor
- Toolbar
- USBDock

01:51:10 pm

- Entstanden als Lehre-Betriebssystem
- Autor: Andrew S. Tanenbaum
- Microkernel-Design
- Lizenz: BSD-ähnlich

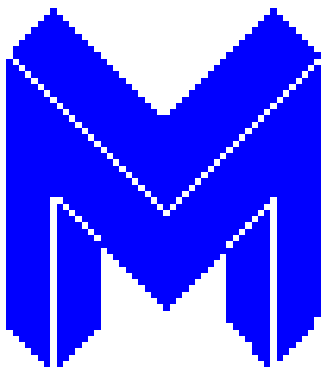

Minix

- Mischung aus GNU-Userland und Darwin-Kern
- Darwin: Unterbau von MacOS X
- Lizenz: GPL / APSL

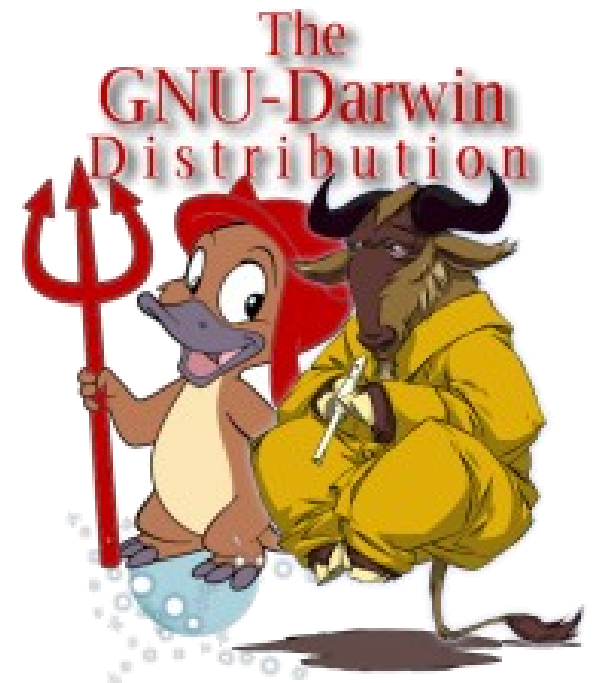

GNU/Hurd

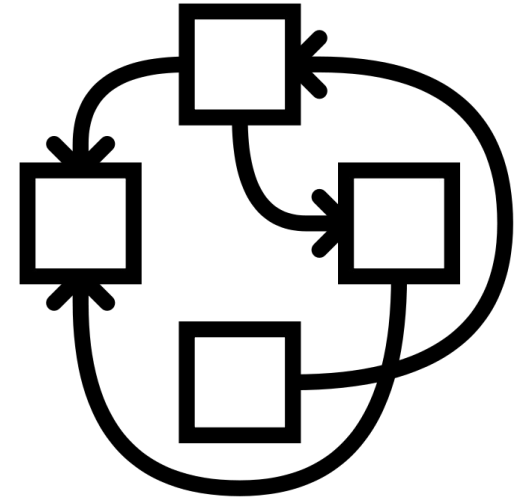

- GNU-Ersatz für Unix-Kernel
- Basierend auf dem Mach-Mikrokern
- The Hurd is firstly a collection of protocols formalizing how different components may interact. The protocols are designed to reduce the mutual trust requirements of the actors thereby permitting a more extensible system. These include interface definitions to manipulate files and directories and to resolve path names. This allows any process to implement a file system. The only requirement is that it have access to its backing store and that the principal that started it own the file system node to which it connects.
- Lizenz: GPL

- Gemeinsame Wurzel: BSD
- Freie Unix-Variante(n)
- Lizenz: BSD (d'oh!)

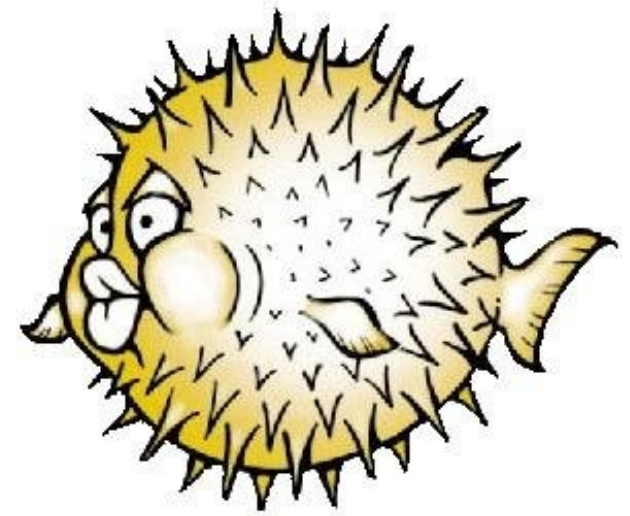

OpenBSD



FreeBSD



opensolaris™



- Ehemals Solaris, davor SunOS
- Sun hätte gerne Entwickler
- Lizenz: CDDL

Das war's!

- Noch Fragen?
- Ansonsten: VMs anschauen?